

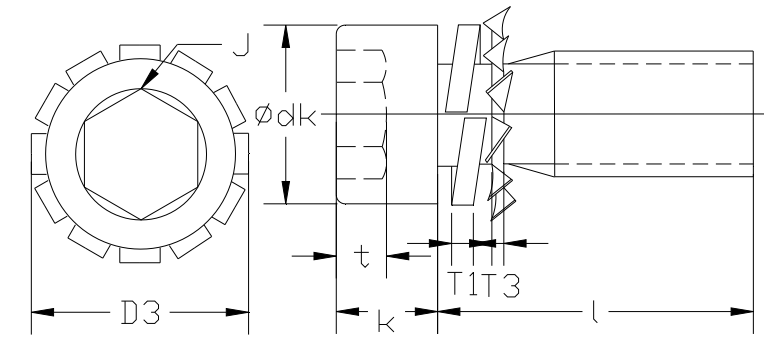

三 等 重 企 業 有 限 公 司  
重 慶 仁 華 街 6 9 號

TEL : 02-28577979 FAX : 02-28579292

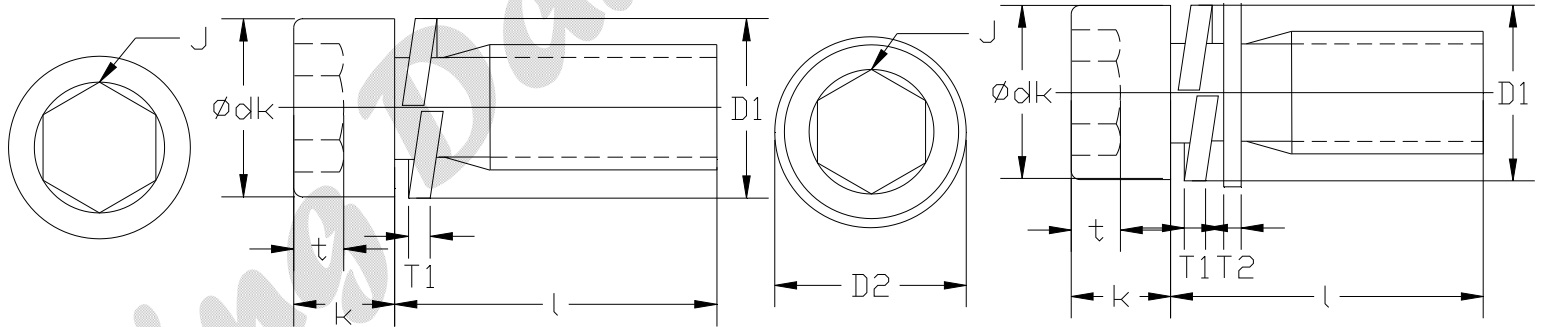

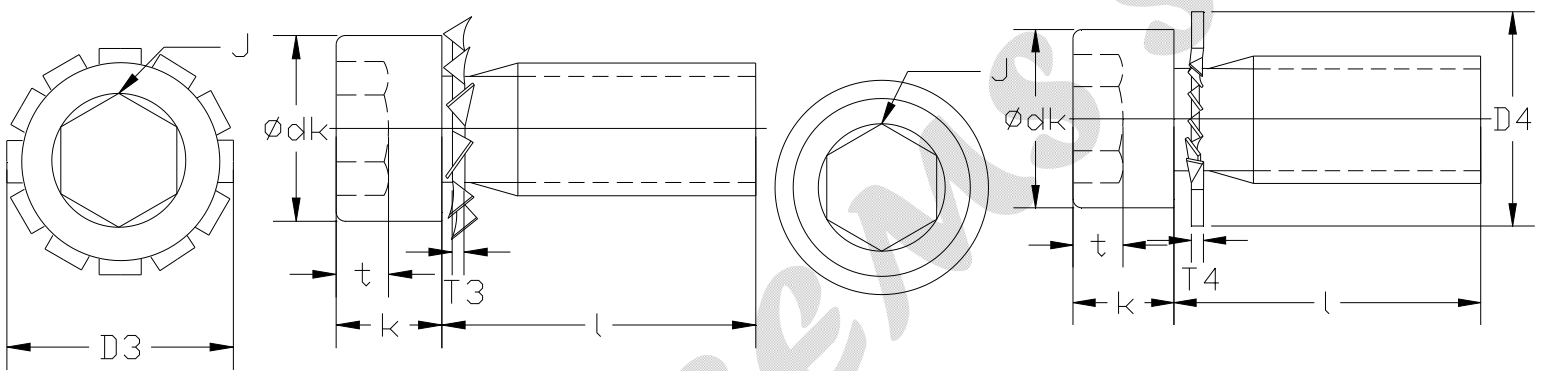
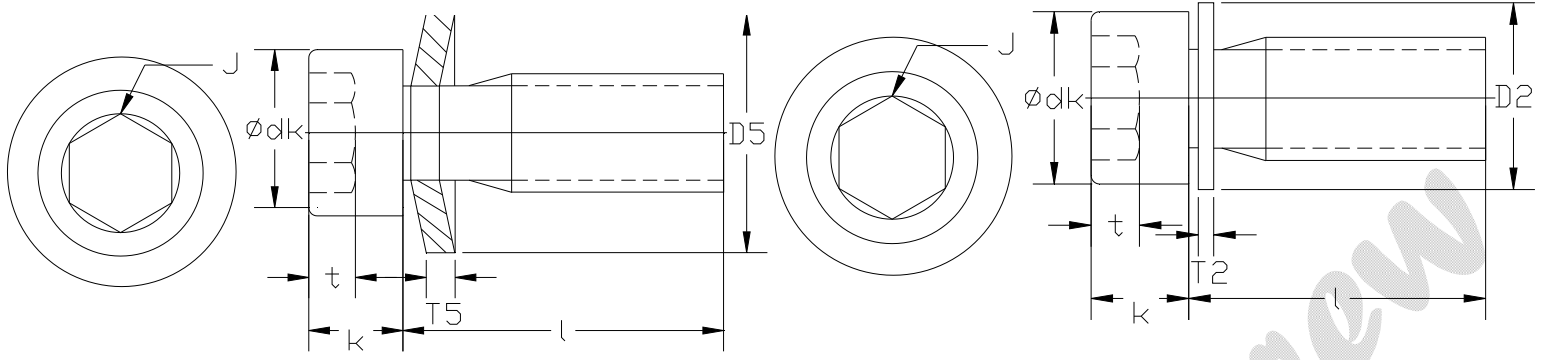

單位 INCH

Nominal Size or Basic Screw Diameter			2	3	4	5	6	8	10	1/4	5/16
			0.0860	0.0990	0.1120	0.1250	0.1380	0.1640	0.1900	0.2500	0.3125
dk	Head Diameter	Max	0.140	0.161	0.183	0.205	0.226	0.270	0.312	0.375	0.469
		Min	0.134	0.154	0.176	0.198	0.218	0.262	0.303	0.365	0.457
k	Head Height	Max	0.086	0.099	0.112	0.125	0.138	0.164	0.190	0.250	0.312
		Min	0.083	0.095	0.108	0.121	0.134	0.159	0.185	0.244	0.306
J	Hexagon Socket Size	Nom	5/64	5/64	3/32	3/32	7/64	9/64	5/32	3/16	1/4
			0.078	0.078	0.094	0.094	0.109	0.141	0.156	0.188	0.250
t	Key engagement	Min	0.038	0.044	0.051	0.057	0.064	0.077	0.090	0.120	0.151

附註：

1. 參考 IFI ANSI/ASME B18.3
2. 彈簧華司請參閱 IFI ANSI/ASME B18.13
3. 平華司請參閱 IFI ANSI/ASME B18.22.1
4. 內（外）齒請參閱 IFI ANSI/ASME B18.13

Ping Dan SEMS